

GYMNASTICS BAR INSTRUCTION

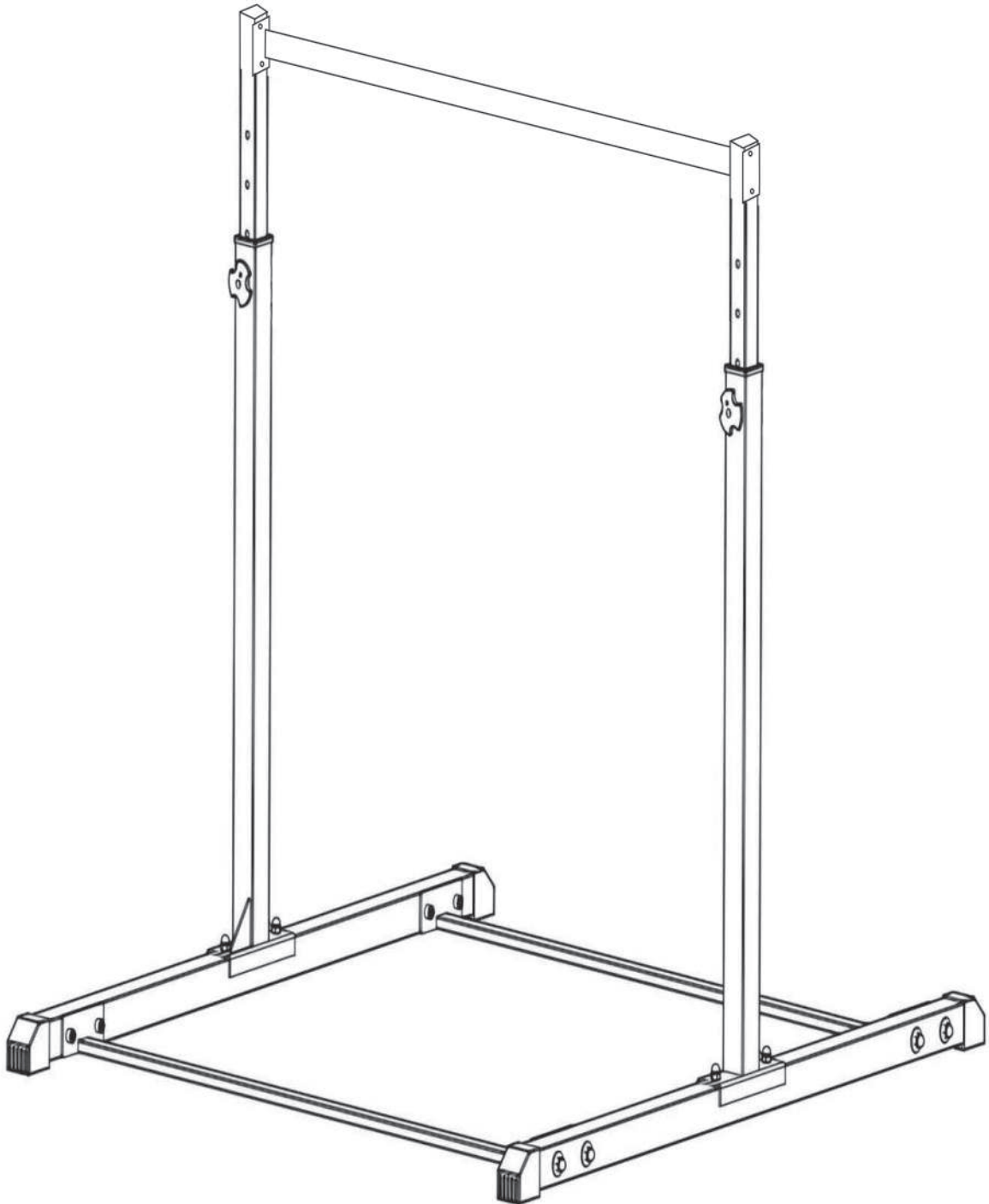

E-mail: support@saflyfun.com

SAFETY INFORMATION

- Adults supervision is required for people under 18 when assembling.
- Take care of any sharp edges of parts to avoid scratching.
- Please take care that there are no children around when you assembling.
- Use it only on stable and even surfaces.
- Regularly check the tightness of all screws.
- Do not knock the machine with hard subjects.
- Do not use volatile oil,thinner or other organic solvent to clean dirt.
- Do not use this machine in moisture place.
- Before using it,please do warm exercise for 5 to 10 minutes.
- Do not wear any jewelry when you using this machine.
- Make sure there is no people around when using it.
- Please wear suitable clothes when exercising.
- Do not over exert yourself.Take a break and have some water in time.
- Physical weakness,please avoid using it.
- Do not use this product immediately after meals.
- If you experience any pain or unusual discomfort during exercise,stop your workout at once and consult a physician before continuing.
- When you receive this product, please stop using it immediately if you find it damaged, so as not to cause unnecessary damage.

If any questions,please contact us:

E-mail: support@saflyfun.com

ATTACHMENT PARTS

#1 Main Frame
#2 Lifting Adjustment Frame

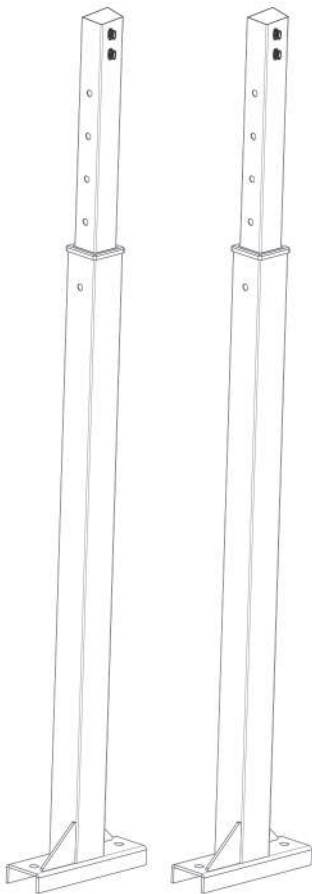

2PCS

#3 Bottom Tube

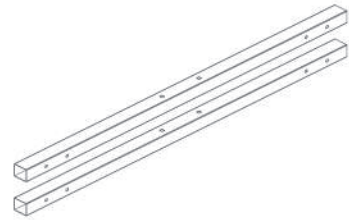

2PCS

#4 Connection Frame



2PCS

#5 Bar

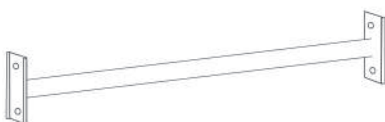

1PCS

#6 Rubber Cover

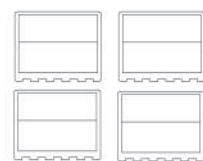

4PCS

#7 Plastic Shank Bolt



M8*60MM
2PCS

#8 Plastic Shank Nut

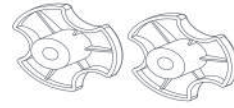

M8
2PCS

#9 Carriage Bolt Set

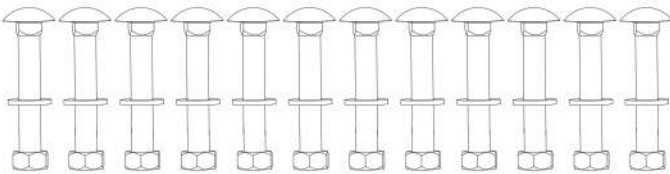

M10*65MM
12PCS

#10 Iron Plate

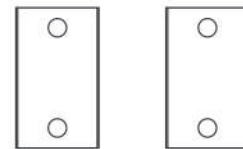

2PCS

#11 External Hexagon Wrench

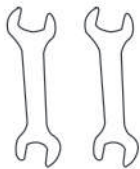

2PCS

#12 Iron Plate

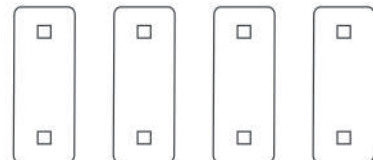

4PCS

#13 External Hex Bolt

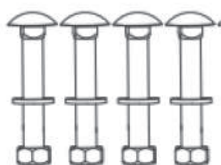

4PCS

Installation Instructions:

Step 1: Install the Rubber Cover

Install the **#3 Bottom Tube** and **#6 Rubber Cover** as shown.

(**Note:** Do not install in the opposite direction)

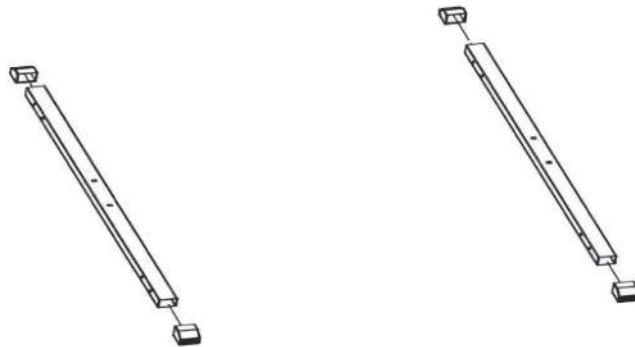

Step 2: Install the Bottom Tube and Main Frame

Connect the assembled Bottom Tube and factory assembled Main Frame (Main Frame and Lifting Adjustment Frame) using

#9 Carriage Bolt Set as shown.

(**Note:** Do not tighten the screws here for now)

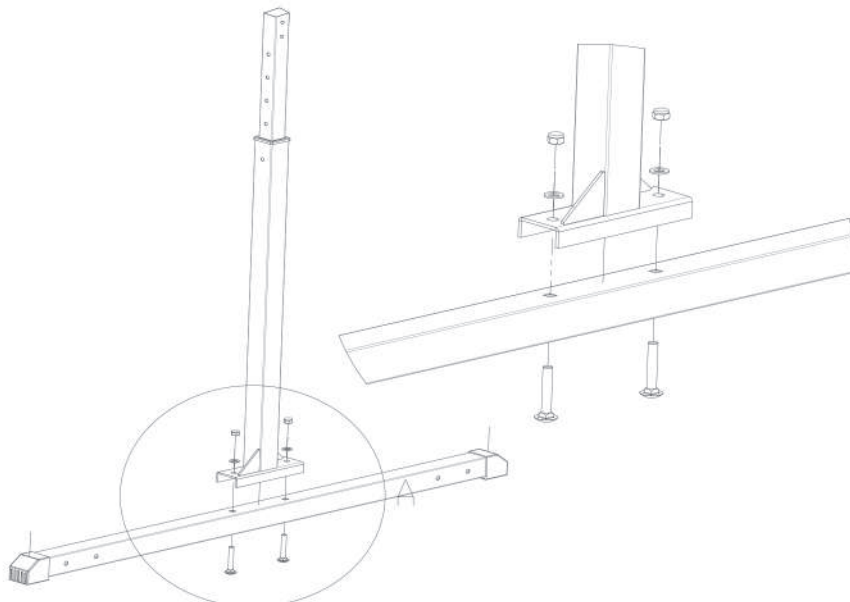

Step 3: Install the Connection Frame

Connect the **#4 Connection Frame** with the assembled (Main Frame, Lifting Adjustment Frame, Bottom Tube) using the **#9 Carriage Bolt Set** as shown.

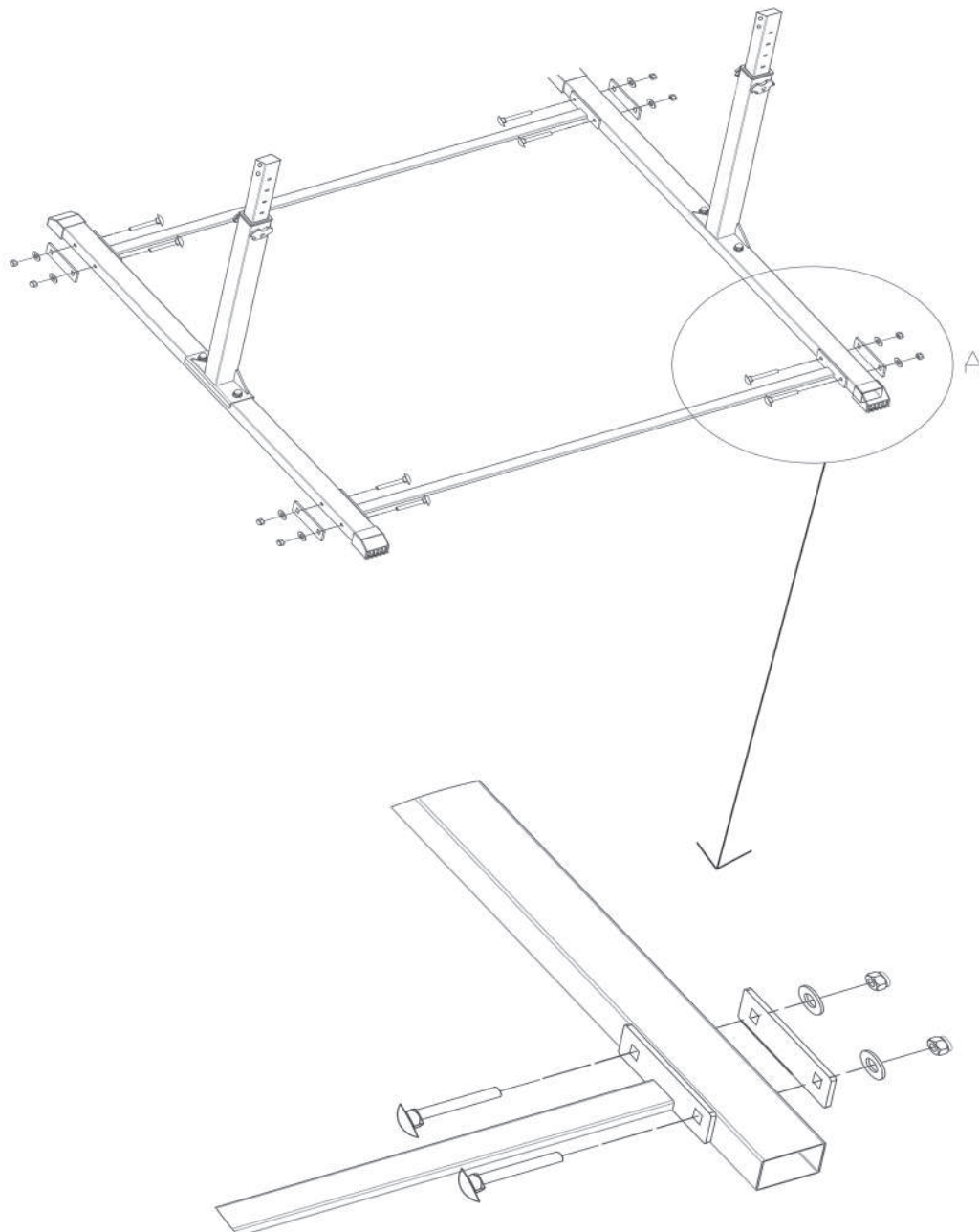

Step 4: Install the Bar

Connect the **#5 Bar** with the assembled (Main frame, Lifting Adjustment Frame, Bottom Tube, Connection Fame) using the **#13 External Hex Bolt** as shown.

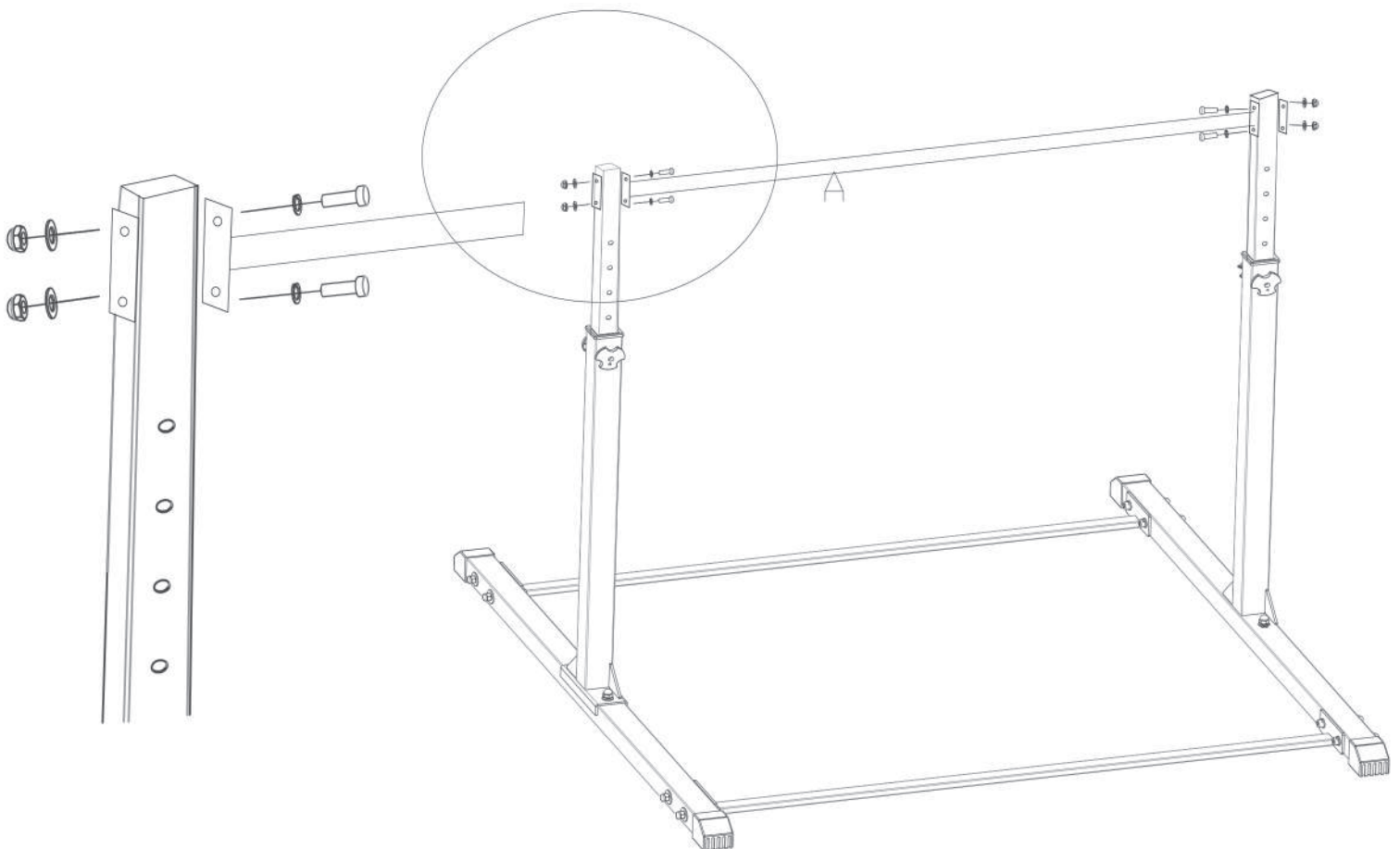

Step 5: Install the Plastic Shank Bolt and Nut

As shown, after adjusting to the desired height by Lifting Adjustment Frame, fix it with #7, #8 accessories. Finally tighten all the screws with a tool.

(Note:Check all screws and tighten them, and prevent instability)

