

Children's Folding Gymnastics Bar

Product model: **GB-DG-01**

Installation instruction:

- Please check the parts list to ensure that all pieces have arrived in good condition.
- Please follow the installation steps. If you have any questions, feel free to contact us at any time.

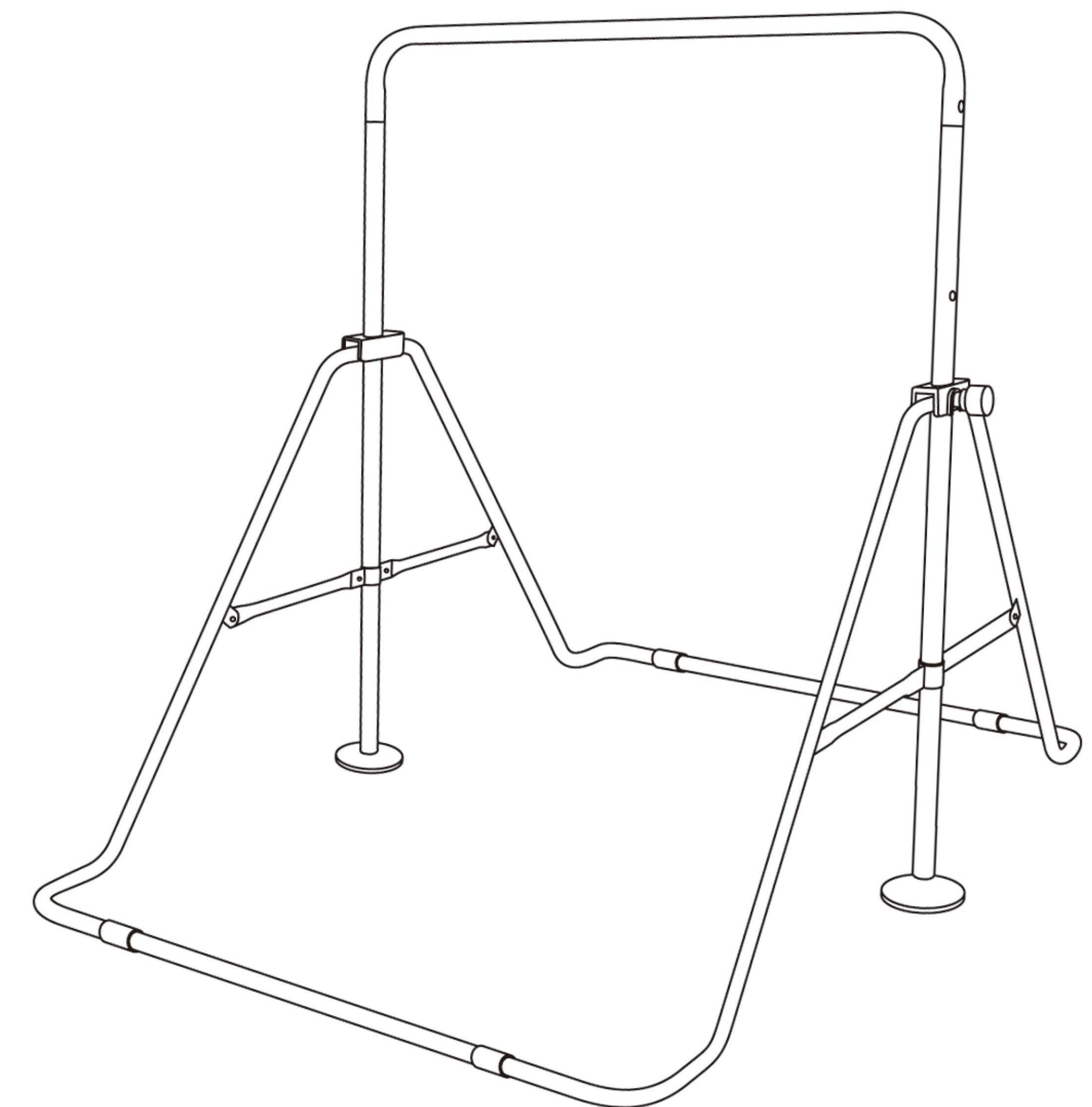

Please contact us at:
service@saflyfun.com

Parts List

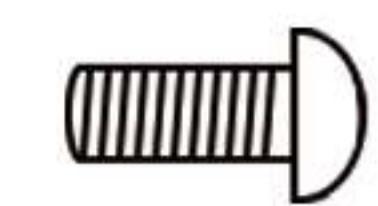
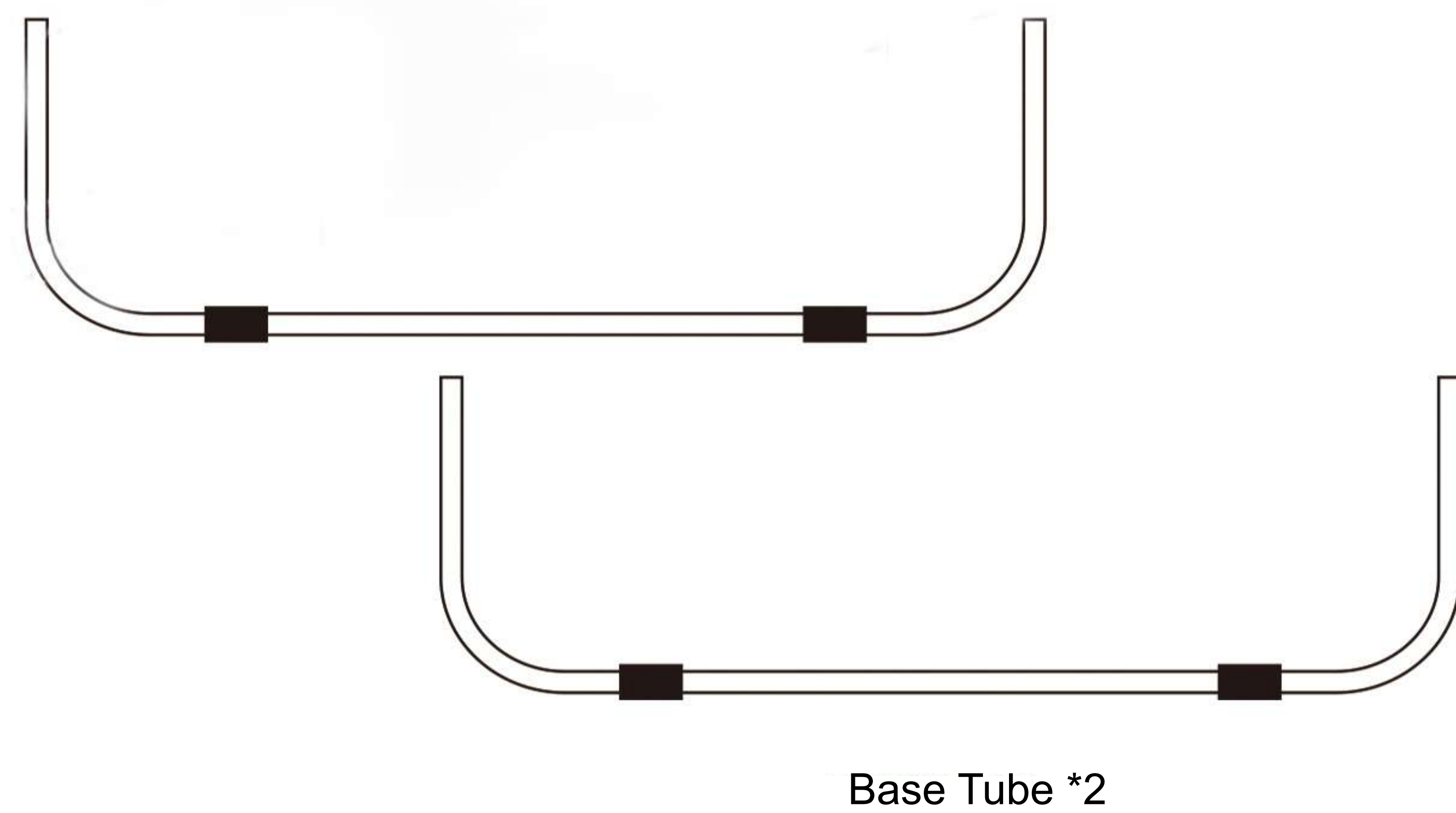
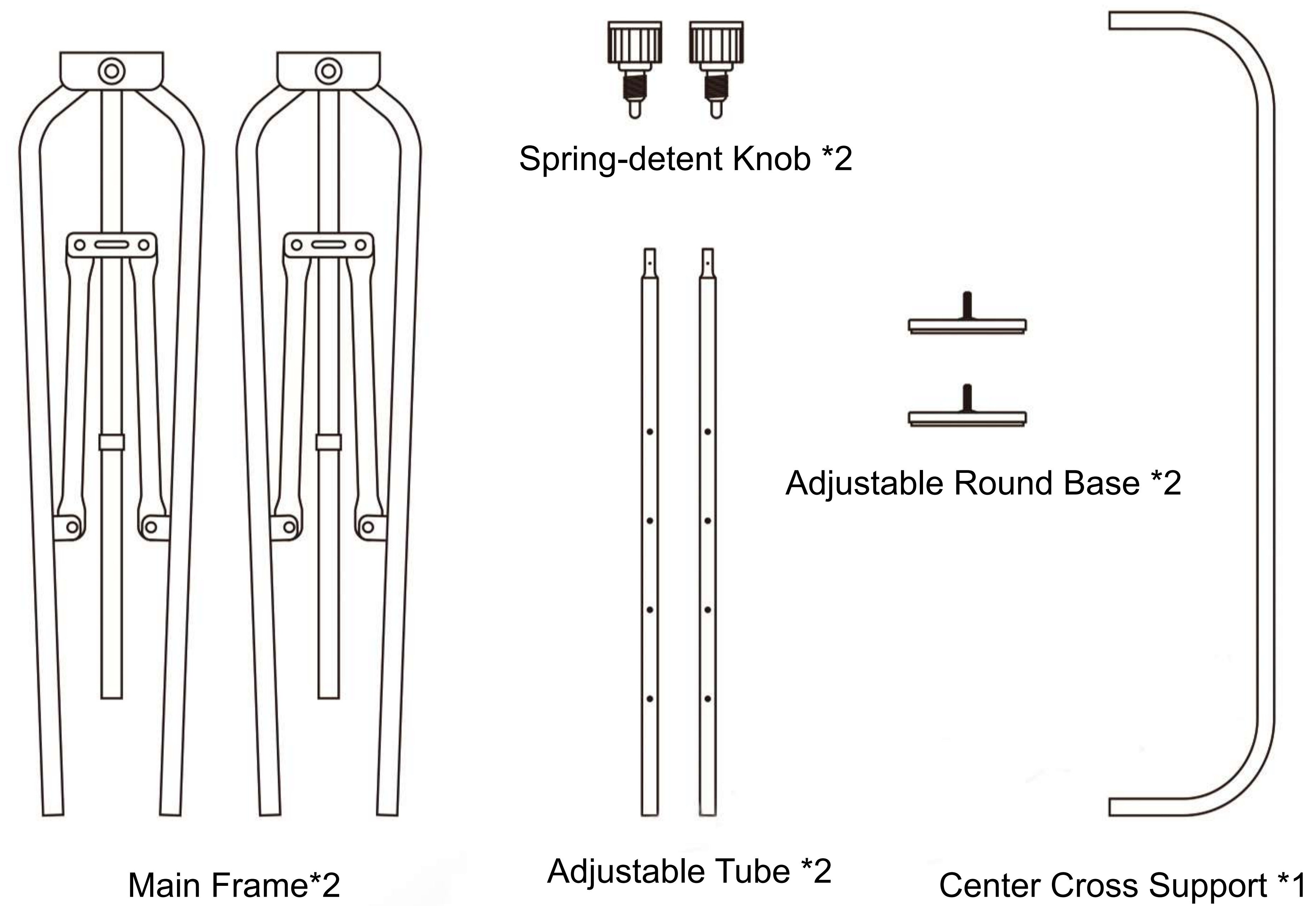

- M6x14mm Screw : 6
- Allen Wrench*1

1

Parts Name

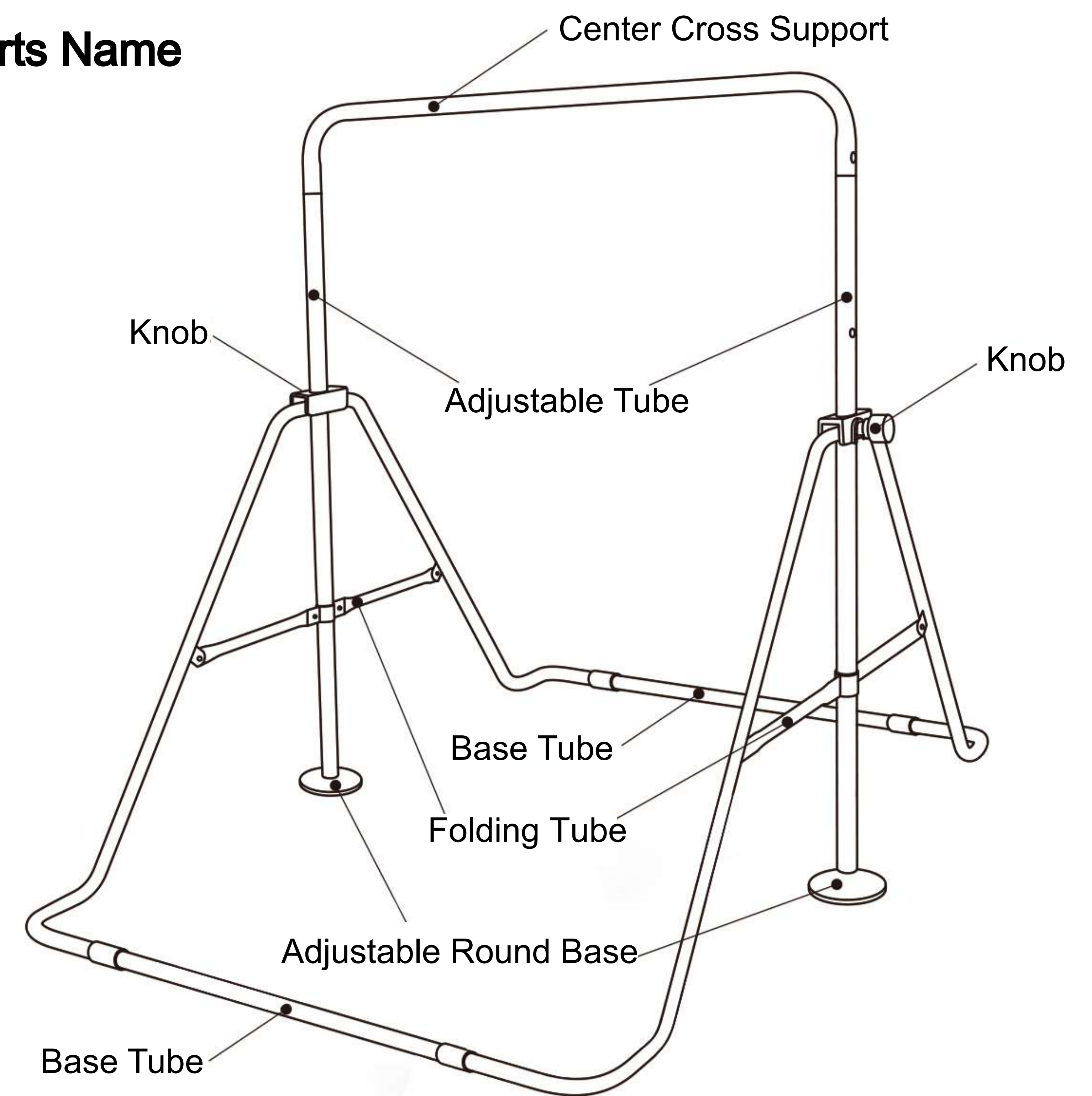

Assembly Instructions

※ For safer installation, we recommend that two people assemble this gymnastics bar together.

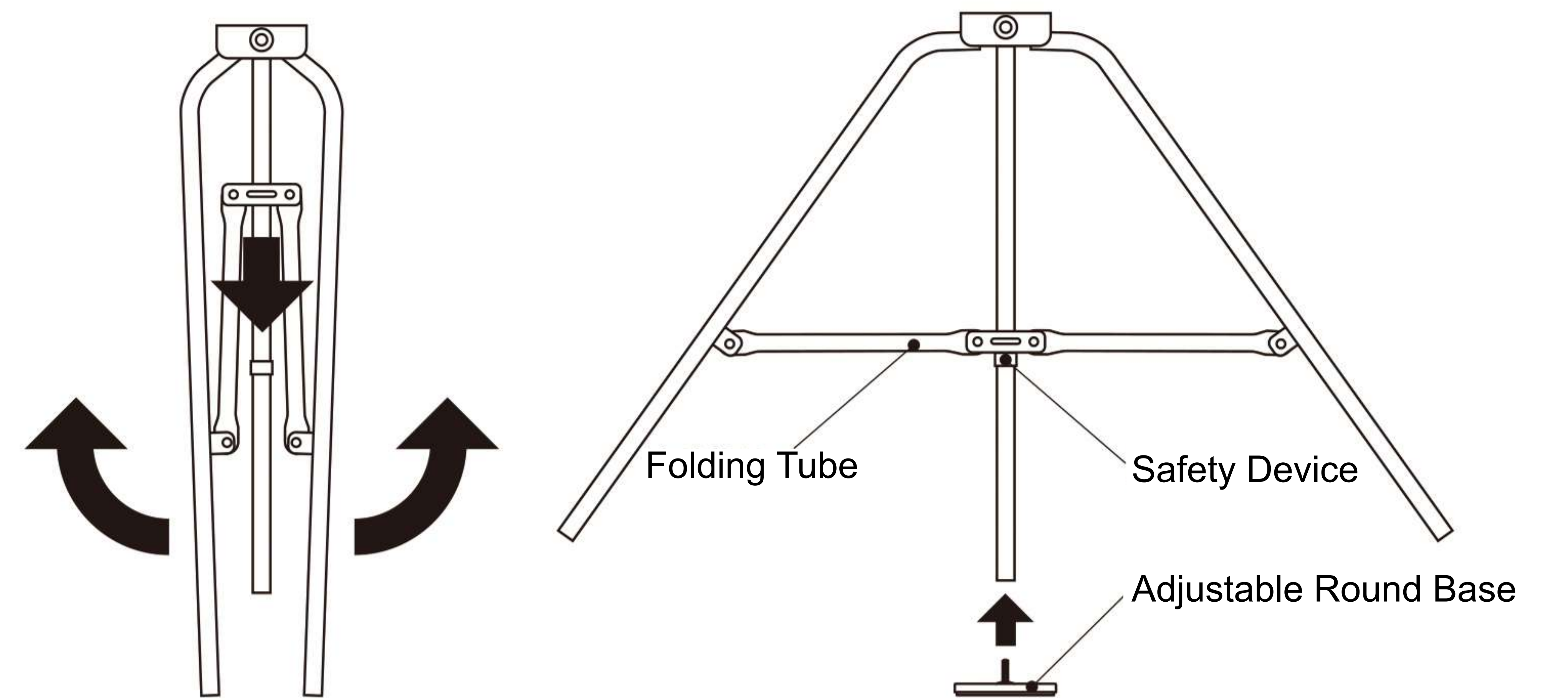

- Open the main frame, then install the round base.

2

■ Assembly Instructions

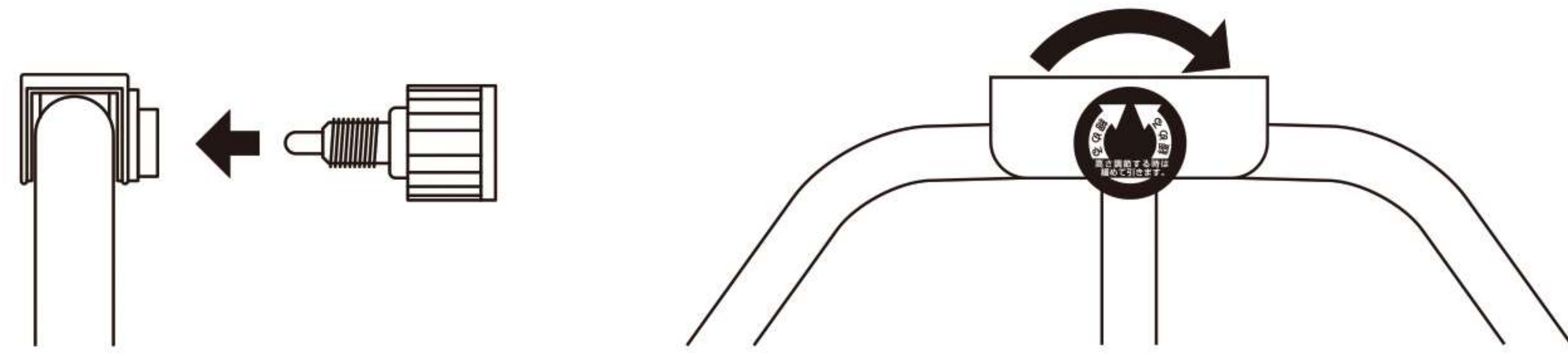

- Screw The Knob

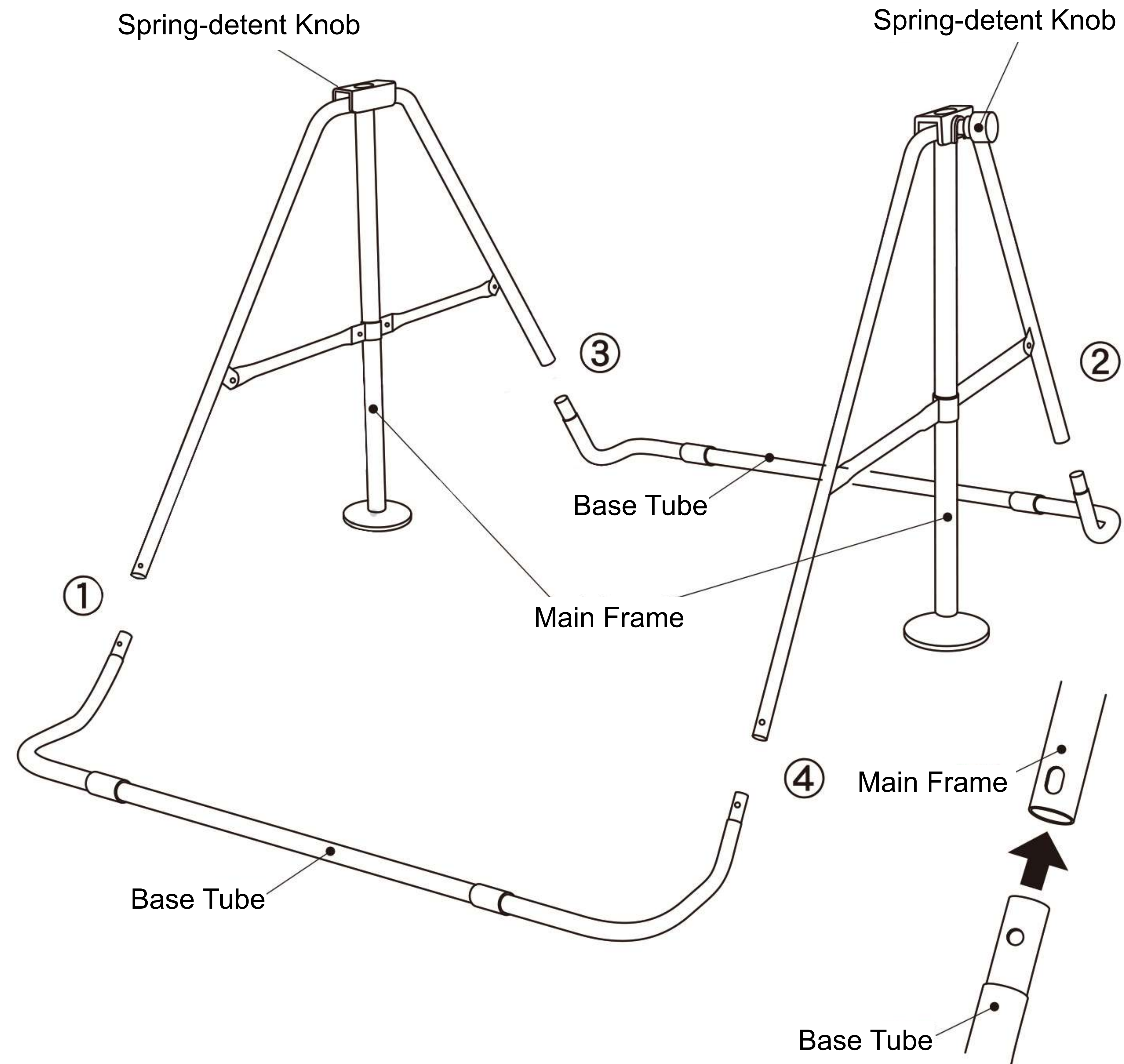

- Notice: Ensure the main frame and spring-detent knobs are facing outward; otherwise, the adjustable tube cannot be installed. Please install these 4 parts in the following order: ①.②.③.④.

3

■ Assembly Instructions

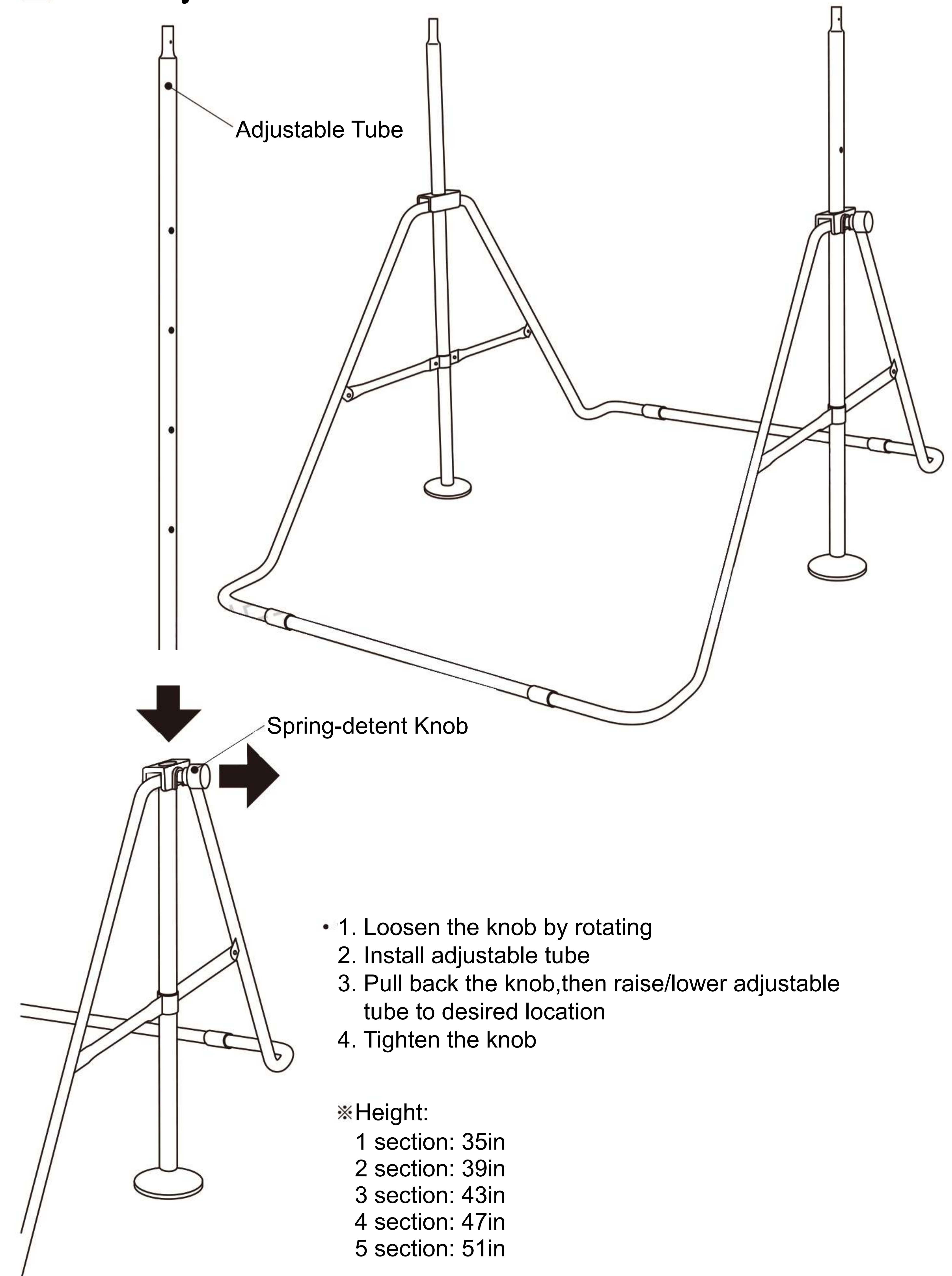

- 1. Loosen the knob by rotating
- 2. Install adjustable tube
- 3. Pull back the knob, then raise/lower adjustable tube to desired location
- 4. Tighten the knob

- ※Height:
- 1 section: 35in
 - 2 section: 39in
 - 3 section: 43in
 - 4 section: 47in
 - 5 section: 51in

4

■ Assembly Instructions

● Illustration

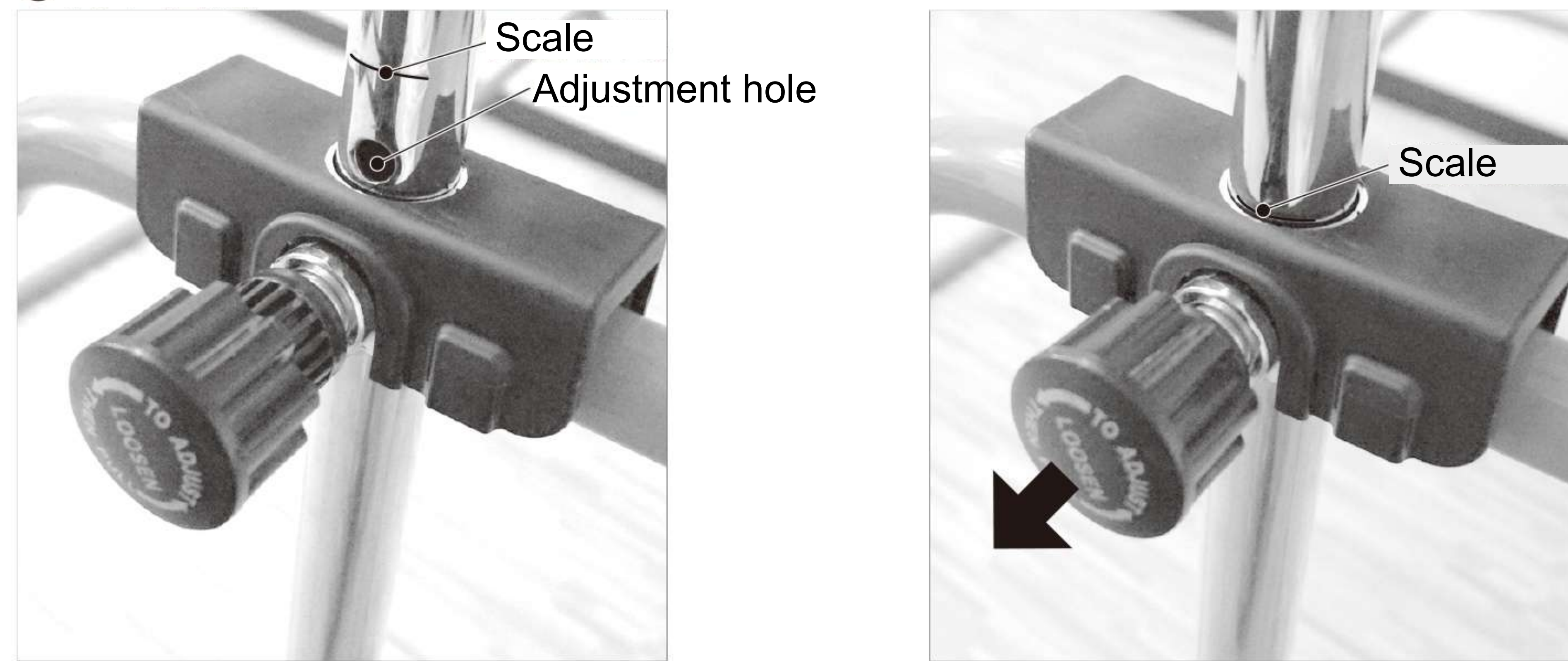

Loosen the knob then pull it back; adjustable tube to different height; push knob back and screw it.

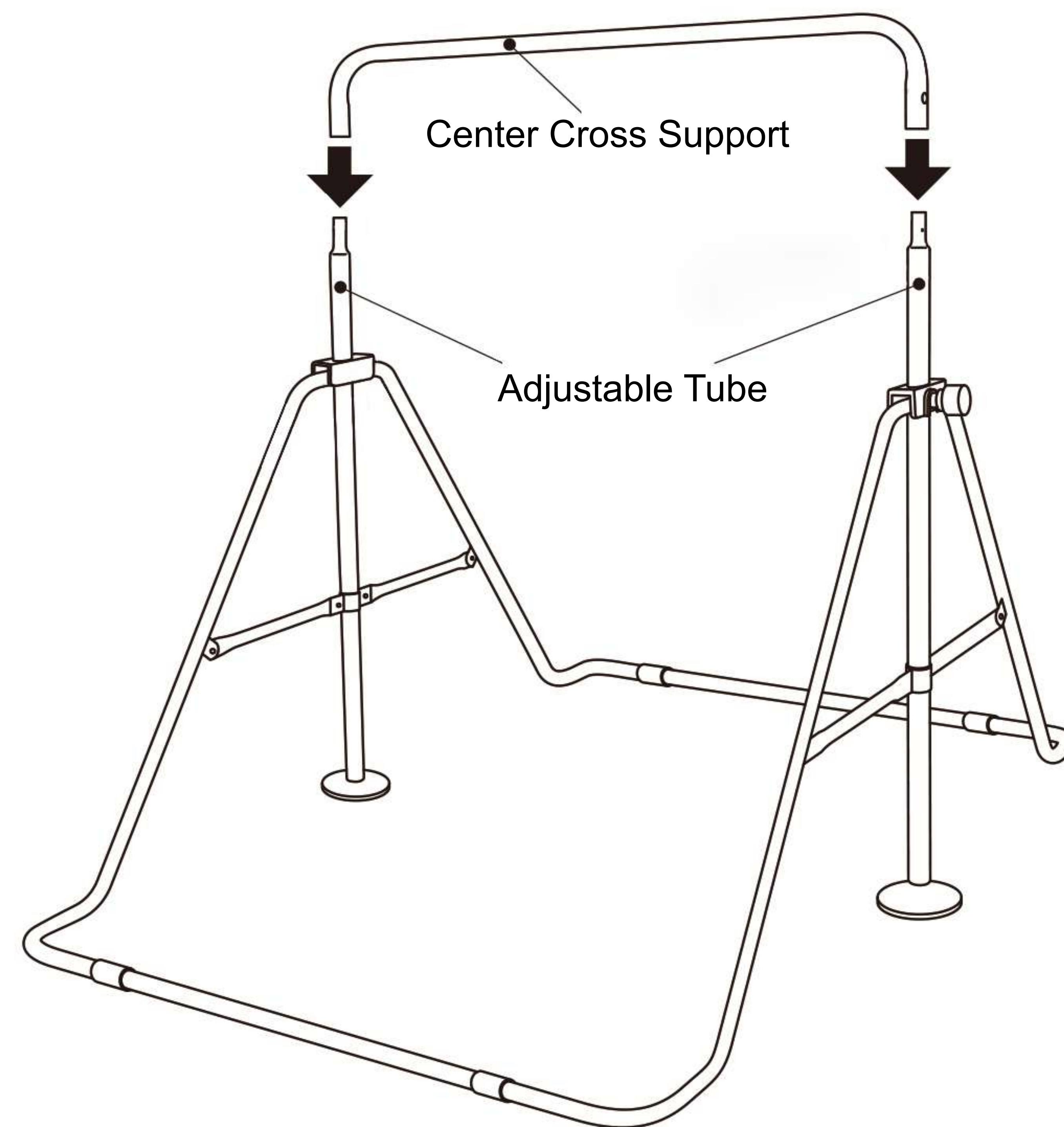

Connect the center cross support with adjustable tube by screw

5

■ Height Adjustment

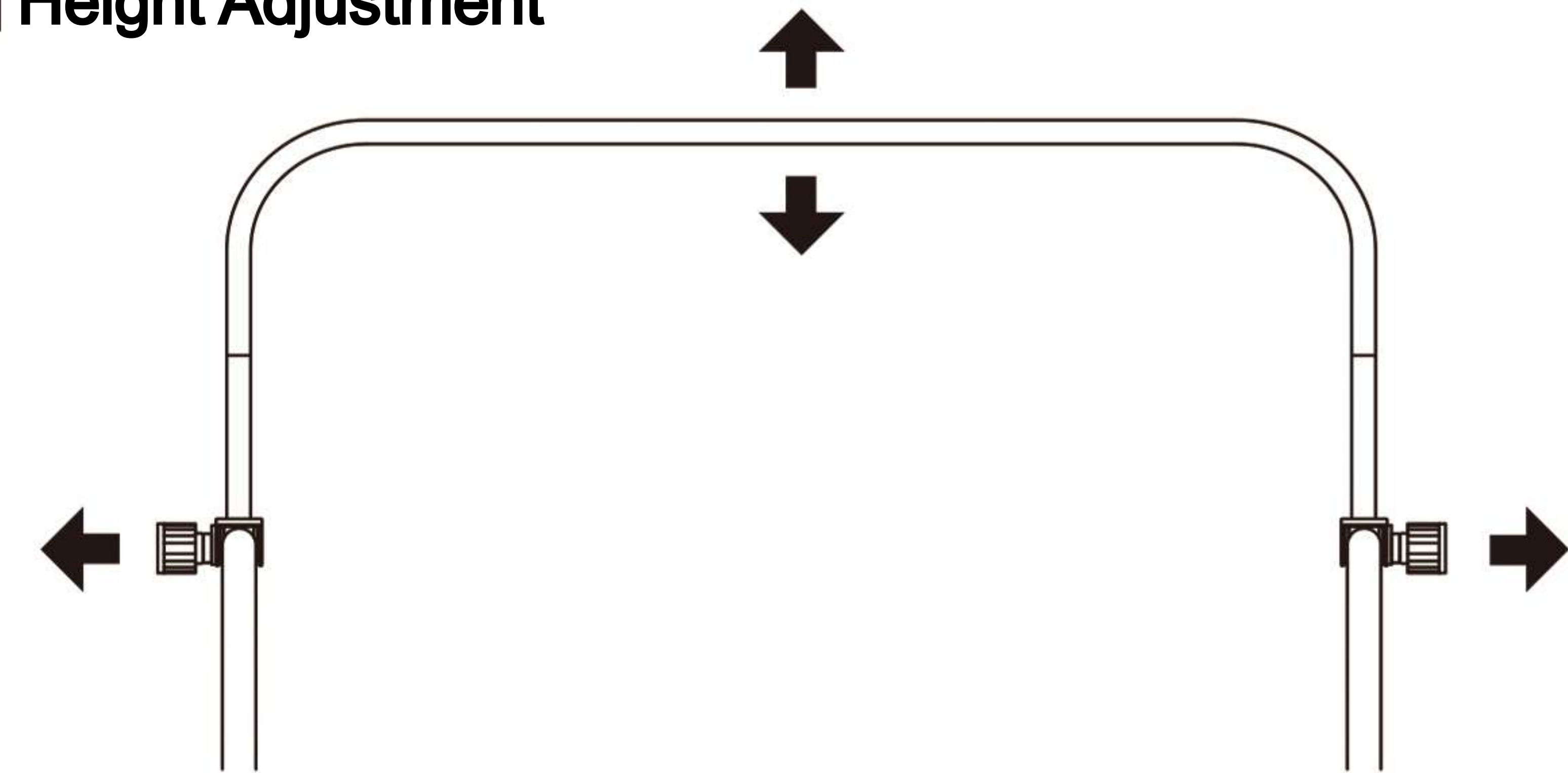

• Knobs: release two knobs, then pull it when the adjustable tube can be turned.

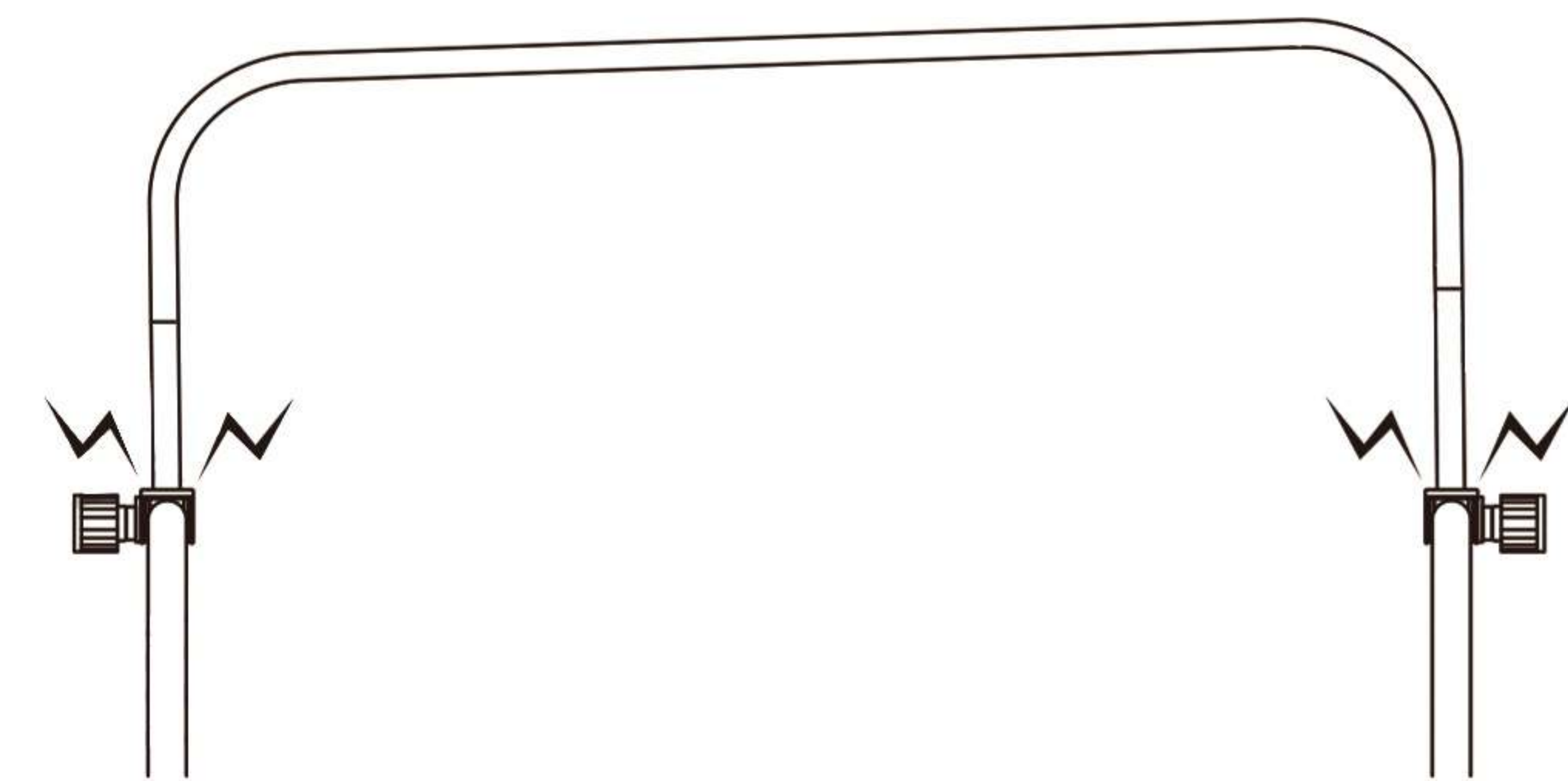

⚠ After both sides of the adjustment are at the same level (refer to scale) push knobs and screw them

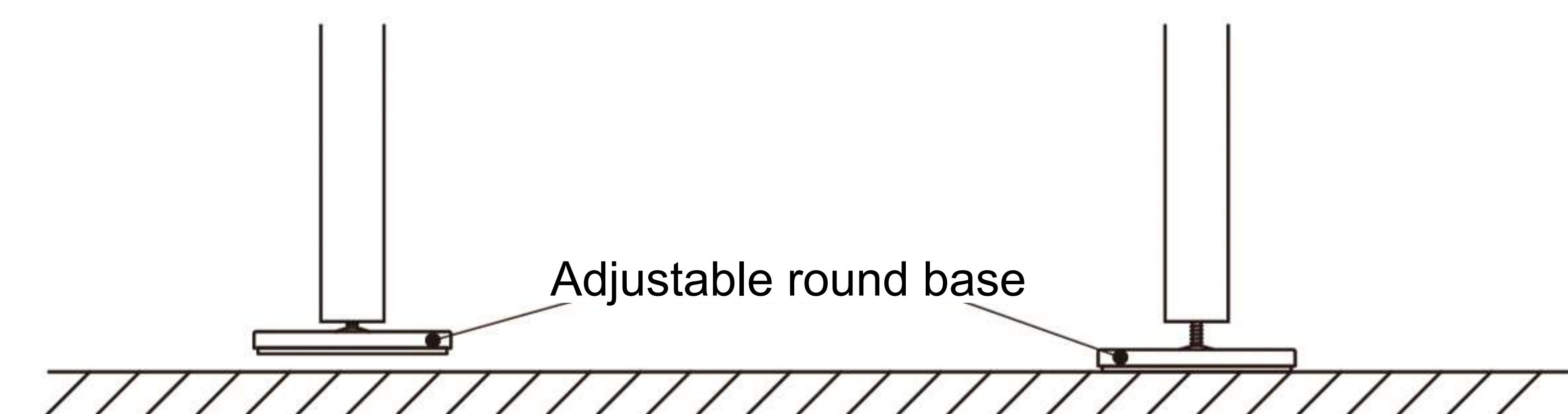

• Adjustable round base: If ground is not flat, you can adjust round base to make gymnastics bar more stable.

6

■ Folding

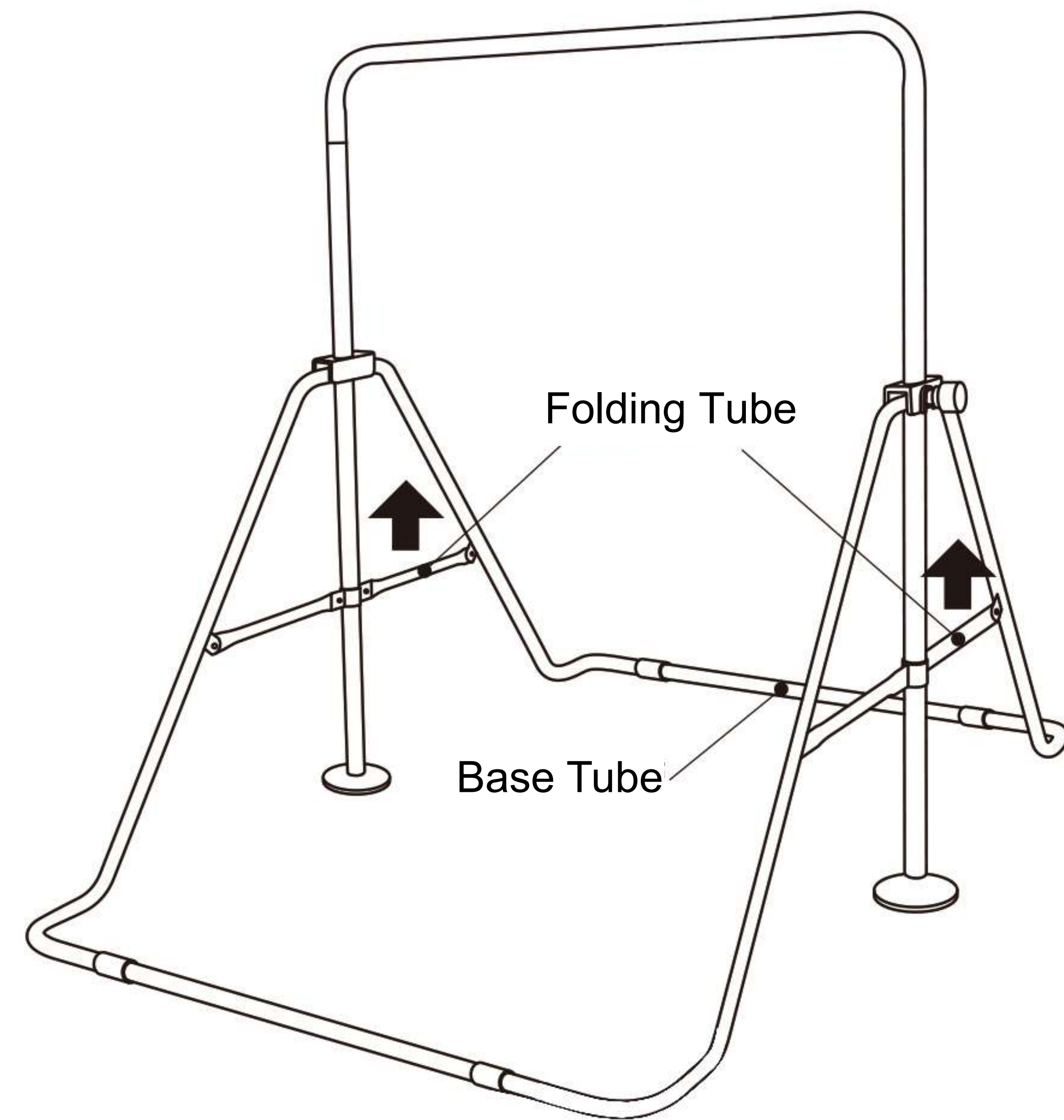

- Hold both two folding tubes and lift them up, then the gymnastics bar folded

